

Town of Mooresville
Facilities and Project Management
413 North Main Street
Mooresville NC 28115
704-555-1707

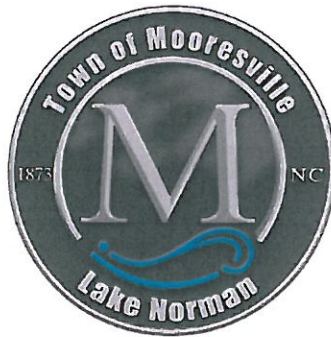

Addendum No.2

Requests for Information

Bid instructions

Sealed bids should be submitted to the attention of Chris Wyckoff – Director of Facilities Town of Mooresville. 413 North Main Street, Mooresville North Carolina, 28115. Bids must have written denotation of their contents on the outside of the sealed envelope.

Sealed bids will be received at the Town of Mooresville, 413 North Main Street, Mooresville, North Carolina 28115 until 1:00 PM on 1/17/2018, at which time the BIDS will be publicly opened and read aloud.

Building Permit

The permit for the project is ready for pick-up with Iredell County. The fee is 1575.76. This fee is the responsibility of the General Contractor. Once Selected, the General Contractor will need to provide Iredell County a Building Application. The project is exempt from a lien Agent, as it is owned by the Town of Mooresville.

Town of Mooresville
Facilities and Project Management
413 North Main Street
Mooresville NC 28115
704-555-1707

Requests for Information

- Re: C2.00 – On the right side of the drawing is a reference/match line for C2.01. There does not appear to be a C2.01 provided.
 - **Answer: there is not a sheet C2.01; please disregard the reference.**
- Re: C3.00 – Where curbing is indicated, the gutter portion is not shown. Are the new curbs in accordance with the detail provided?
 - **Answer: The extent of the new curb and gutter at Liberty Street is limited to that illustrated on the plan sheet C3.00. There is no curb and gutter at the asphalt paving fire turn around.**
 - **There is curb and gutter indicated and called out on Church Street and at the new accessible parking spaces in the existing parking lot.**
- Re: C3.00 – At the Liberty St. tie-in, notes refer to curb and gutter, however no C&G is shown.
 - **Answer: see above.**
- Detail 1/9.00 is for walks. No walks shown.
 - **Answer: refer to detail 2/C9.00 for Town of Mooresville standard curb and gutter.**
- On sheet 9.01 detail 4, there are two details for concrete paving. Is any of the site concrete on the project required to have the vehicular load section, or is it all pedestrian load?
 - **Answer: There is not any heavy duty/vehicular load concrete on the project.**
- What is the profile/paving detail for the street repair for the utility tap location?
 - **Answer: Please see the street paving component of Detail #5/C9.30.**
- Is there a list of owner supplied/contractor installed items in the specs?
 - **Answer: There are supplied/customer owned light poles for the site lighting located throughout. The specs for these lights are attached.**

Submitted



Chris Wyckoff

Facilities Director Town of Mooresville

413 North Main Street Mooresville, NC. 28115

cwyckoff@mooresvillenc.gov

703-798-0408

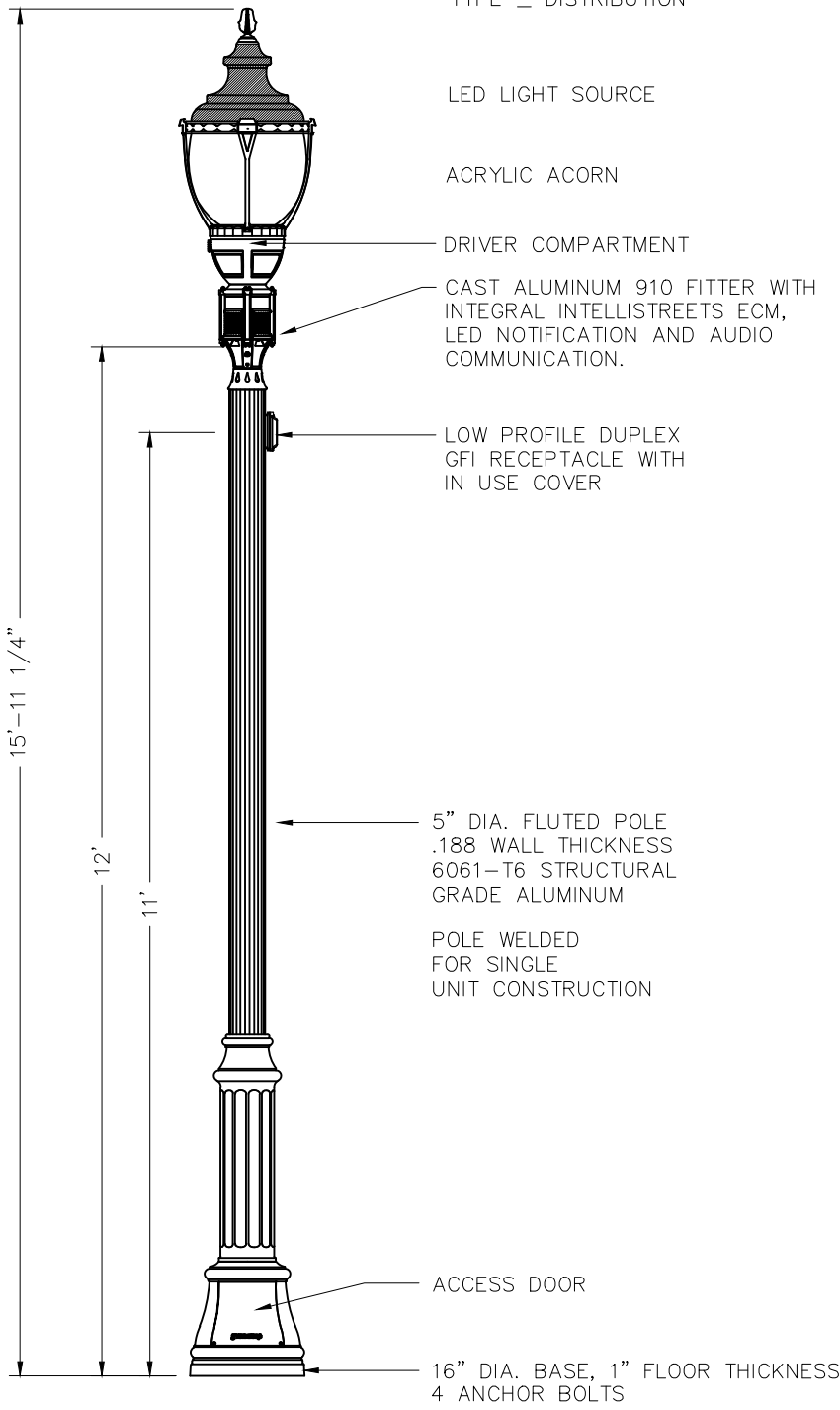
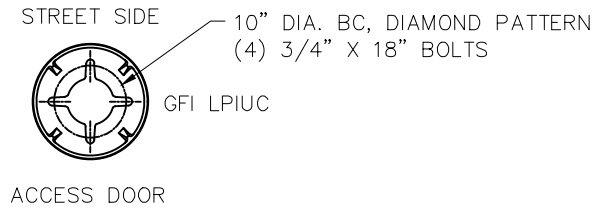

LED SOURCE
 6ARC35T_
 84 LED'S,
 96w, 3,500K
 TYPE _ DISTRIBUTION

LED LIGHT SOURCE

ACRYLIC ACORN

DRIVER COMPARTMENT

CAST ALUMINUM 910 FITTER WITH INTEGRAL INTELLISTREETS ECM, LED NOTIFICATION AND AUDIO COMMUNICATION.

LOW PROFILE DUPLEX GFI RECEPTACLE WITH IN USE COVER

5" DIA. FLUTED POLE
 .188 WALL THICKNESS
 6061-T6 STRUCTURAL GRADE ALUMINUM

POLE WELDED FOR SINGLE UNIT CONSTRUCTION

ACCESS DOOR

16" DIA. BASE, 1" FLOOR THICKNESS
 4 ANCHOR BOLTS

REV	REVISIONS	DATE	RVSD	MOORESVILLE, NC MOORESVILLE, NC	DRAWN JG
A	ORIGINAL	8/1/18		PT-A880SRLED-910-3-6ARC35T_-MDL03-A/7712FP5/GFI LPIUC/BKT	SCALE

DRAWING NUMBER
 SC31655

POLE HEIGHTS HAVE
 A TOLERANCE OF
 + OR - 2"



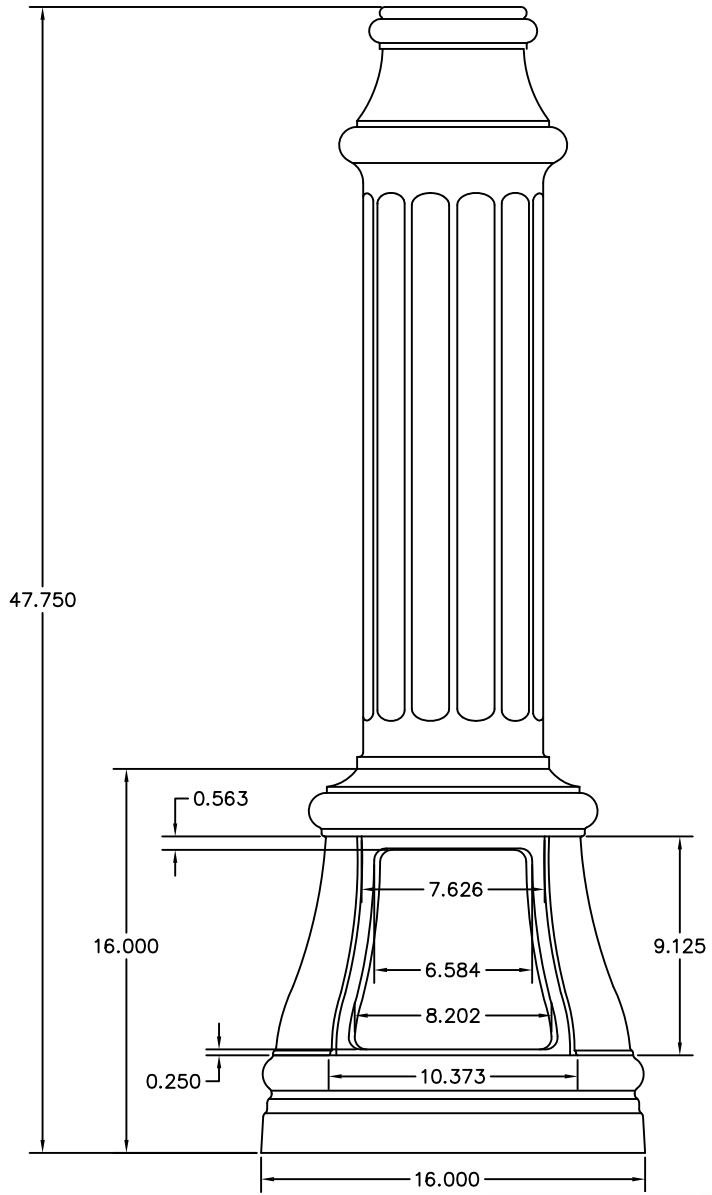
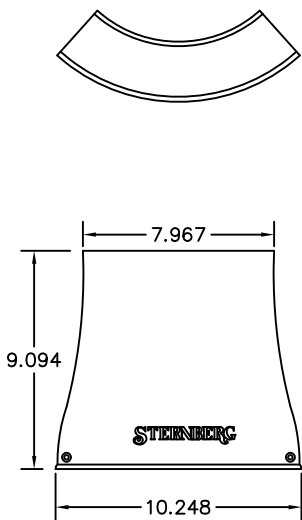

intelli**streets**™

STERNBERG
SINCE 1923

7701-7702
POLE BASE AND ACCESS DOOR

DRAWN	SS
DRAWN DATE	2/5/09
DRAWING NUMBER	

1:8